

BJERRING

BJERRING

**PVC Skalsæder
& PVC Bænke**



BJERRING - Tykhøjvej 20 – Hal 5 – 7323 Give – Tlf. +45 77345206 –
mail: salg@bjerring-sales.dk – bjerring-sales.dk – sunswim.dk – bjerring-shop.dk –
bjerring-furniture.dk

A2

ASIEN TO INDIVIDUAL SIN RESPALDO
BACKLESS SHELL SEAT

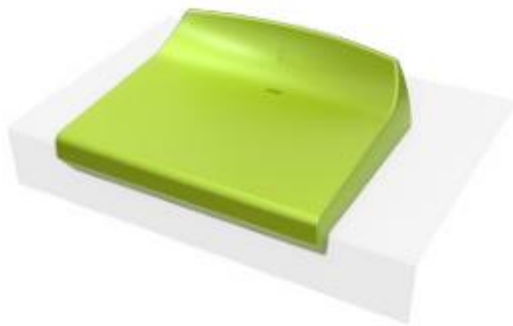

DIMENSIONES
DIMENSIONS

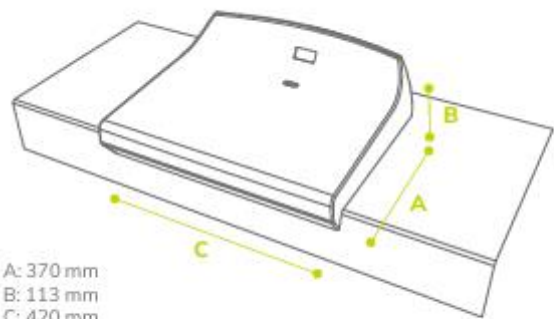

A: 370 mm
B: 113 mm
C: 420 mm

SOBRE GRADA
DIRECTLY ON STEP

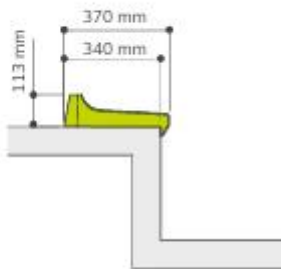

SOBRE BANCO METÁLICO
ON METALLIC BENCH



SOBRE FRENTE DE GRADA
RISER MOUNTED

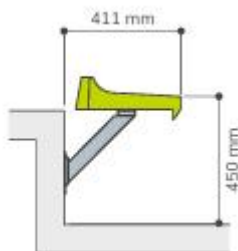

SOBRE PIE DE GRADA
FLOOR MOUNTED

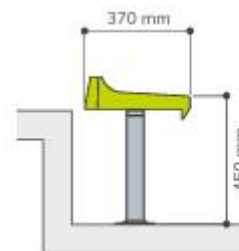

INFORMACIÓN:

Asiento individual sin respaldo, para gradas convencionales y tribunas metálicas (telescópicas o desmontables).

INFORMATION:

Backless shell seat, for conventional and metallic grandstands (telescopic or dismantable).

COMPLEMENTOS COMPLEMENTS

Numeración Numbering

PUNTOS DE ANCLAJE ANCHORING POINTS

1 Punto de anclaje central
1 Central anchoring point



A2
Palacio de deportes de Beaulieu. Nantes Métropole, Francia.
Palais des Sports de Beaulieu. Nantes Métropole, France.

A3

ASIENTO CON DOBLE RESPALDO
DOUBLE-WALL BACKREST SHELL SEAT

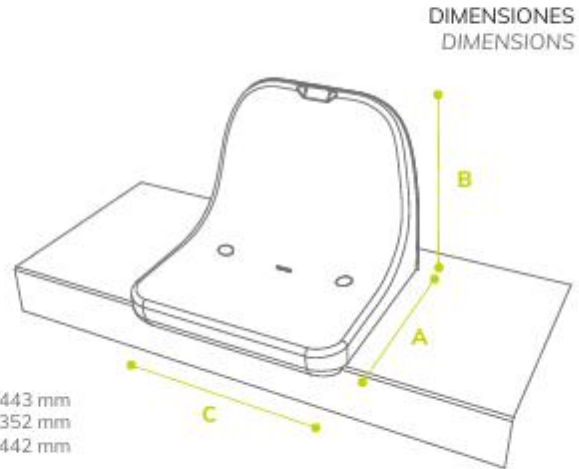

SOBRE GRADA
DIRECTLY ON STEP

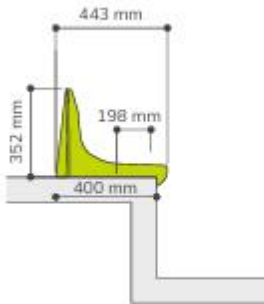

SOBRE BANCO METÁLICO
ON METALLIC BENCH



SOBRE FRENTE DE GRADA
RISER MOUNTED

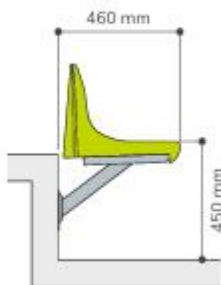

SOBRE PIE DE GRADA
FLOOR MOUNTED

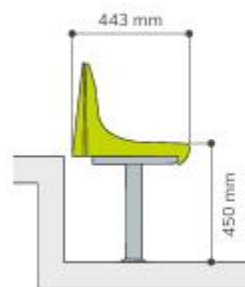

INFORMACIÓN:

Con doble respaldo y altura superior a 35 cm, según recomendaciones de la UEFA /FIFA, para instalar en cualquier tipo de grada, especialmente en zonas de uso muy agresivo. Respaldo ergonómico con zona lumbar pronunciada.

INFORMATION:

With double-wall backrest and 35 cm of backrest height, according with UEFA/FIFA recommendations, for any kind of grandstand, specially for severe public use areas. Ergonomic backrest with lumbar space.

COMPLEMENTOS COMPLEMENTS

Numeración
Numbering

Apoyabrazos
Armrest

PUNTOS DE ANCLAJE ANCHORING POINTS

2 Puntos de anclaje laterales
2 Lateral anchoring points



A3
Dalo Wasabi Stayen Stadium, Bélgica.
Dalo Wasabi Stayen Stadium, Belgium.

CR2

ASIEN TO INDIVIDUAL CON RESPALDO
BACKREST SHELL SEAT

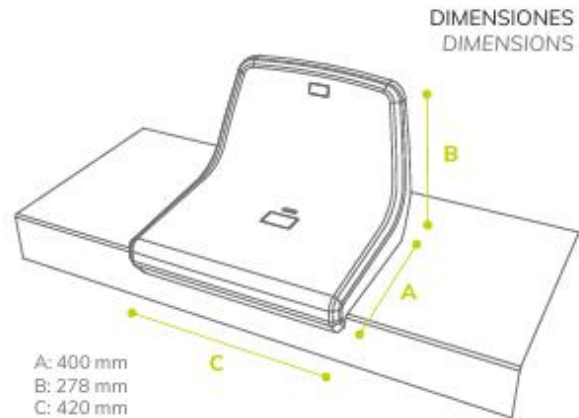

SOBRE GRADA
DIRECTLY ON STEP

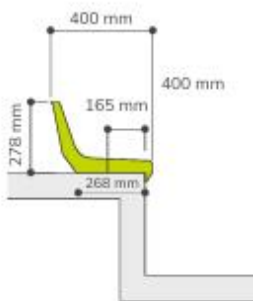

SOBRE BANCO METÁLICO
ON METALLIC BENCH

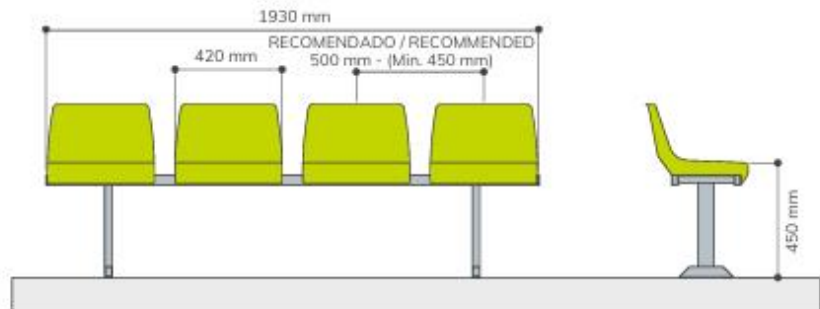

SOBRE FRENTE DE GRADA
RISER MOUNTED

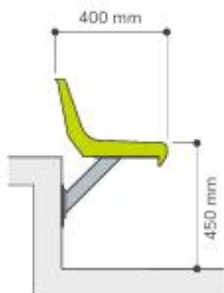

SOBRE PIE DE GRADA
FLOOR MOUNTED

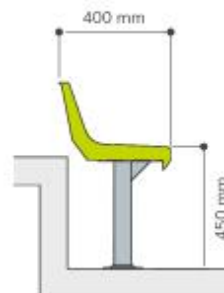

INFORMACIÓN:

Con respaldo medio-alto, para instalar en gradas de huella estrecha, o en centros deportivos multiusos. Compatible para instalar en gradas desmontables o telescópicas.

INFORMATION:

With medium-height backrest, for conventional narrow tread grandstands, or multipurpose sports venues. Compatible for install at dismantlable or telescopic bleachers.

COMPLEMENTOS COMPLEMENTS

Numeración
Numbering

Apoyabrazos
Armrest

PUNTOS DE ANCLAJE ANCHORING POINTS

1 Punto de anclaje central
1 Central anchoring point



CR2
Tai Po Waterfront, Hong Kong,
Tai Po Waterfront, Hong Kong.

CR3

ASIENTO INDIVIDUAL CON RESPALDO
BACKREST SHELL SEAT

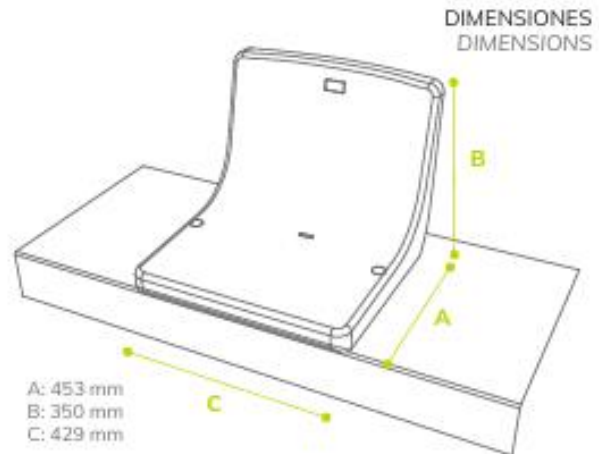

SOBRE GRADA
DIRECTLY ON STEP

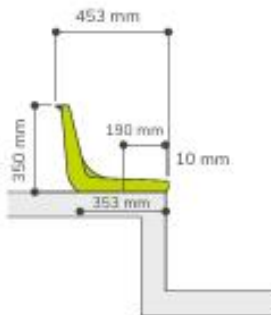

SOBRE BANCO METÁLICO
ON METALLIC BENCH

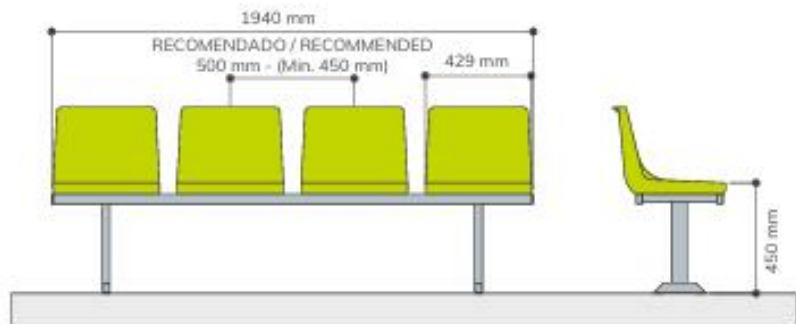

SOBRE FRENTE DE GRADA
RISER MOUNTED

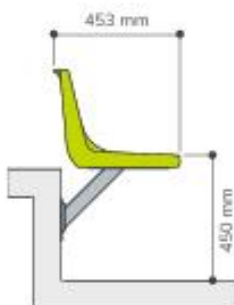

SOBRE PIE DE GRADA
FLOOR MOUNTED



INFORMACIÓN:

Con respaldo alto, según recomendaciones de la UEFA /FIFA, para instalar en cualquier grada convencional.

INFORMATION:

With high backrest, according with UEFA /FIFA recommendations, for conventional grandstands.

COMPLEMENTOS COMPLEMENTS

Numeración
Numbering

Apoyabrazos
Armrest

PUNTOS DE ANCLAJE ANCHORING POINTS

2 Puntos de anclaje laterales
2 Lateral anchoring points

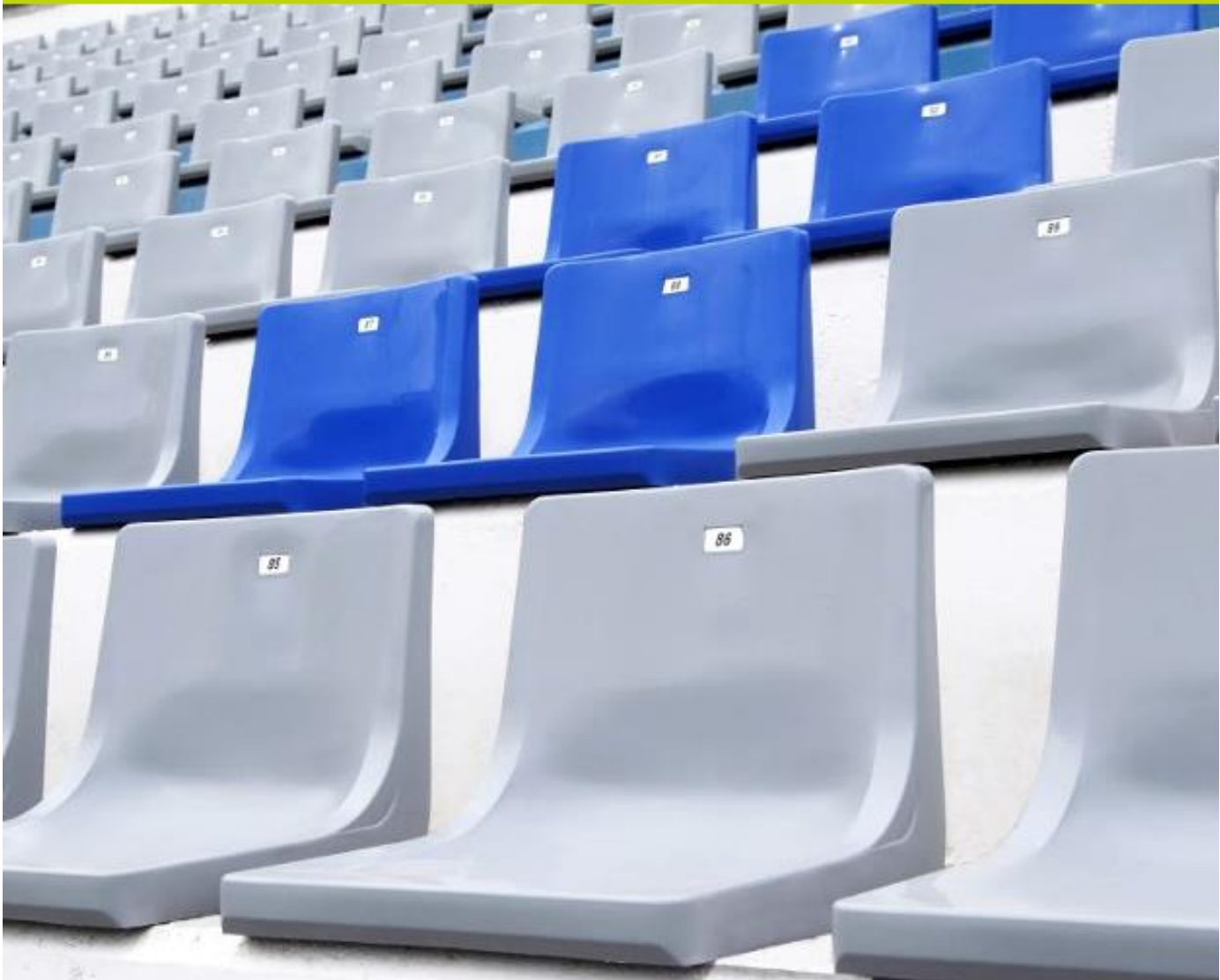

CR3
Estadio Nova Creu Alta, Sabadell, Barcelona, España.
Nova Creu Alta Stadium, Sabadell, Barcelona, Spain.

CR4

ASIENTO INDIVIDUAL CON RESPALDO
BACKREST SHELL SEAT



DIMENSIONES
DIMENSIONS

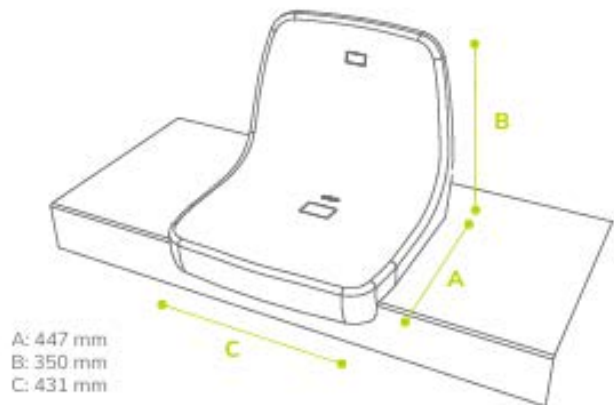

SOBRE GRADA
DIRECTLY ON STEP

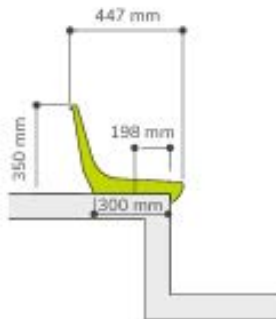

SOBRE BANCO METÁLICO
ON METALLIC BENCH

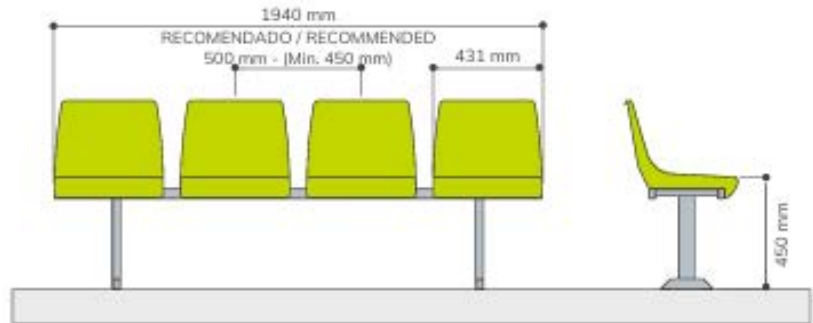

SOBRE FRENTE DE GRADA
RISER MOUNTED

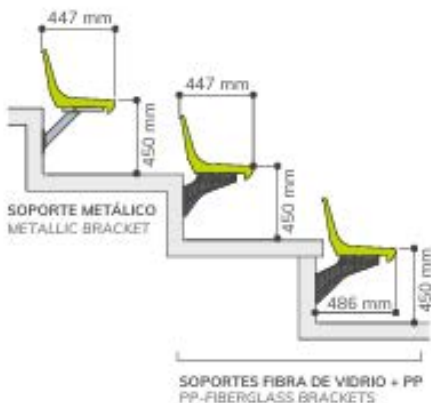

SOBRE PIE DE GRADA
FLOOR MOUNTED

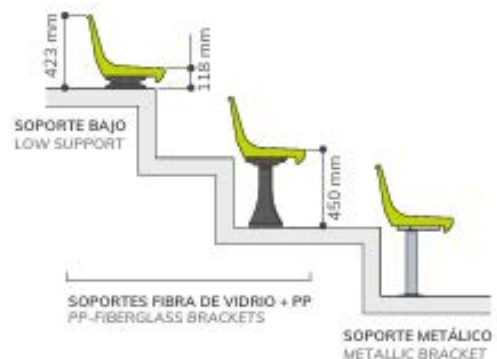

INFORMACIÓN:

Con respaldo alto, según recomendaciones de la UEFA /FIFA, para instalar en cualquier tipo de grada. Admite soportes metálicos y de fibra de vidrio.

INFORMATION:

With high backrest, according with UEFA /FIFA recommendations, for any kind of grandstands. Compatible with metallic and pp+fibreglass brackets.

COMPLEMENTOS COMPLEMENTS

Numeración
Numbering

Apoyabrazos
Armrest

Logo
Logo

Acolchado
Upholstery

PUNTOS DE ANCLAJE ANCHORING POINTS

1 Punto de anclaje central
1 Central anchoring point



CR4
Opap Arena, Atenas, Grecia.
Opap Arena, Athens, Greece.

CR5

ASIENTO INDIVIDUAL CON RESPALDO
BACKREST SHELL SEAT



DIMENSIONES
DIMENSIONS

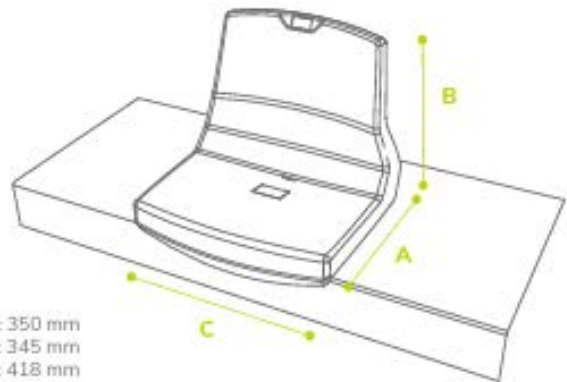

A: 350 mm
B: 345 mm
C: 418 mm

SOBRE GRADA
DIRECTLY ON STEP



RECOMENDADO / RECOMMENDED
500 mm - (Mín. 450 mm)

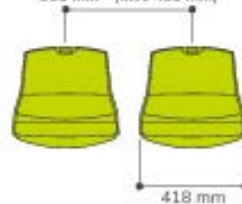

SOBRE FRENTE DE GRADA
RISER MOUNTED

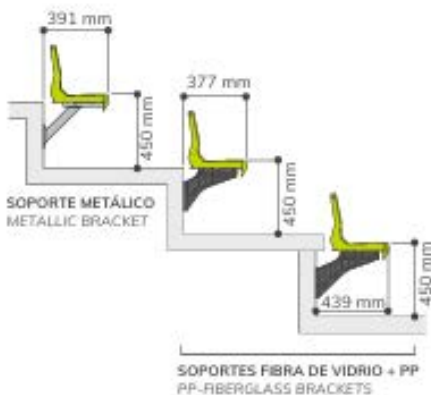

SOBRE PIE DE GRADA
FLOOR MOUNTED

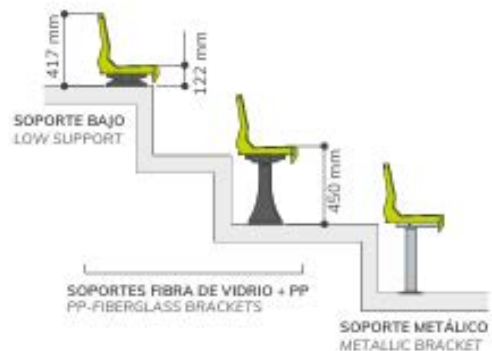

INFORMACIÓN:

Asiento con respaldo alto de 35 cm, siguiendo la recomendación de la UEFA / FIFA para instalaciones deportivas, diseñado especialmente para gradas con huella estrecha, (ocupa sobre la grada sólo 31 cm), que no renuncian a la confortabilidad de un asiento con respaldo (profundidad total: 35 cm).

Admite soportes metálicos y de fibra de vidrio.

INFORMATION:

Monoblock seat with high backrest (35 cm), according with UEFA /FIFA recommendations. It is been specially designed for narrow tread venues (depth seat over concrete: 31 cm), that must fit in small spaces, with a backrest seat.

Compatible with metallic and pp+fibreglass brackets.

COMPLEMENTOS COMPLEMENTS

Numeración
Numbering

Apoyabrazos
Armrest

PUNTOS DE ANCLAJE ANCHORING POINTS

1 Punto de anclaje central
1 Central anchoring point



CR5
Estadio Benito Villamarín, Sevilla, España.
Benito Villamarín Stadium, Seville, Spain.

CR6

ASIEN TO INDIVIDUAL CON RESPALDO
BACKREST SHELL SEAT



DIMENSIONES
DIMENSIONS

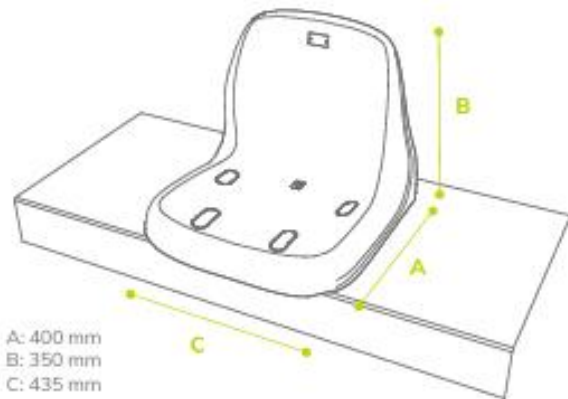

A: 400 mm
B: 350 mm
C: 435 mm

SOBRE GRADA
DIRECTLY ON STEP

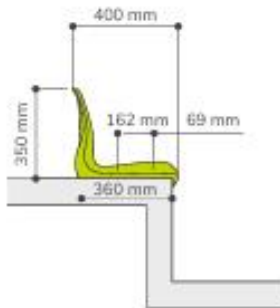

RECOMENDADO / RECOMMENDED
500 mm - (Min. 450 mm)

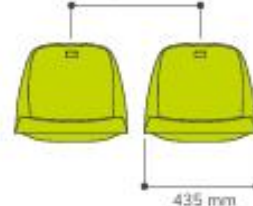

SOBRE FRENTE DE GRADA
RISER MOUNTED

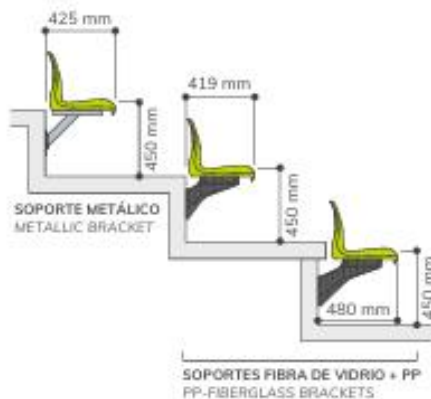

SOBRE PIE DE GRADA
FLOOR MOUNTED



INFORMACIÓN:

Asiento con respaldo alto de 35 cm, siguiendo la recomendación de la UEFA / FIFA para estadios de primer nivel. Con superficie acabada en texturizado mate. El asiento se puede anclar con 2 o con 4 puntos de fijación al suelo. Admite soportes metálicos y de fibra de vidrio.

INFORMATION:

Monoblock seat with high backrest (35 cm), according with UEFA /FIFA recommendations for UEFA competitions. Seat finished in textured matte surface. The seat could be installed by 2 or 4 anchoring points to the concrete. Compatible with metallic and pp+fibreglass brackets.

COMPLEMENTOS COMPLEMENTS

Numeración
Numbering

Apoyabrazos
Armrest

PUNTOS DE ANCLAJE ANCHORING POINTS

2 Puntos de anclaje laterales
2 Lateral anchoring points

4 Puntos de anclaje
4 anchoring points



CR6
Estadio Ciutat de València, UD Levante, Valencia, España.
Ciutat de Valencia Stadium, UD Levante, Valencia, Spain.

CRM

ASIENTO INDIVIDUAL CON RESPALDO
BACKREST SHELL SEAT

DIMENSIONES
DIMENSIONS

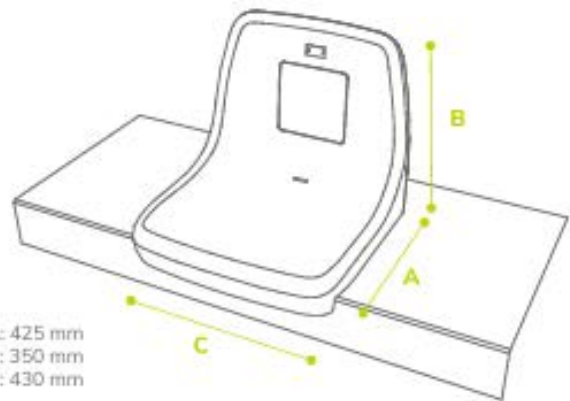

SOBRE GRADA
DIRECTLY ON STEP

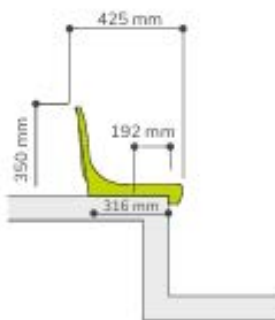

SOBRE BANCO METÁLICO
ON METALLIC BENCH

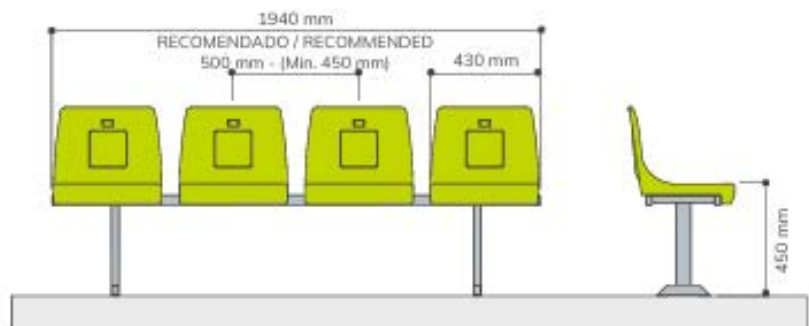

SOBRE FRENTE DE GRADA
RISER MOUNTED

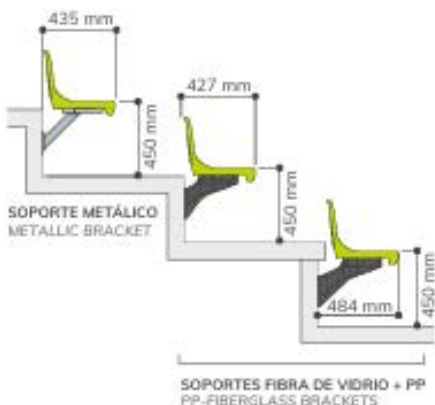

SOBRE PIE DE GRADA
FLOOR MOUNTED

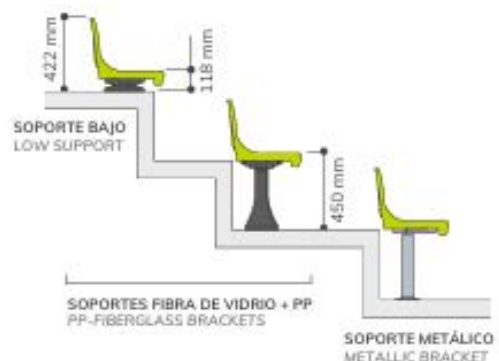

INFORMACIÓN:

Con respaldo alto, según recomendaciones de la UEFA /FIFA, para instalaciones grandes o para gradas convencionales de huella estrecha. Admite soportes metálicos y de fibra de vidrio. Asiento con diseño ergonómico. Opción de insertar un escudo o logo en relieve en el respaldo.

INFORMATION:

With high backrest, according with UEFA /FIFA recommendations, with smooth desing, for usage in big venues or venues with narrow tread grandstands. Compatible with metallic and pp+fibreglass brackets. Ergonomic and optionally with logo in backrest of seat.

COMPLEMENTOS COMPLEMENTS

Numeración
Numbering

Apoyabrazos
Armrest

Logo
Logo

Acolchado
Upholstery

PUNTOS DE ANCLAJE ANCHORING POINTS

1 Punto de anclaje central
1 Central anchoring point



CRM
Sportboulevard Dordrecht, Países Bajos.
Sportboulevard Dordrecht, Netherlands.

Sitwooden

BJERRING

Set formed by seat and metallic bracket for use in multi-purpose arenas, stadiums and sports facilities in general, all indoor venues.



Set formed by seat and metallic bracket for use in multi-purpose arenas, stadiums and sports facilities in general, all indoor venues.

Sitwooden allows you to adapt a comfortable posture thanks to the flexibility of wood and its regular proportions. With rounded edges and corners, Sitwooden model seat allows freedom of movement meanwhile you are enjoying an active event such as sports.

Wood stadium seat. It is a seating solution designed for indoor sports venues that, according to their architecture atmosphere, requires a warm and natural environment in their grandstands.

Daplast Seating features a different stadia seat designed for sports facilities, made from wood but very resistant and functional, according to the regulations required by UNE – EN 12727: 2017 Aligned Seats, level 2.

Sitwooden is installed to the grandstand through a solid metallic bracket. The fixing system is totally below the seat surface.

Numbering is located on one side of the backrest, in low relief, allowing to check quickly the own locality.

Sitwooden is ideal for integrate at indoor architecture complex thanks to its regular and minimal shapes.

Its appearance with regular shapes and without formal complications makes it the best solution for integration into the interior architecture of the complex. The contrast of the wood grain and the solid color of the rest of the seat highlights its natural connotation in an equipment that has always been very industrial in sports equipment.

Seat dimensions:

- 430 x 417 x 465 mm.

Accessories:

- Numbering plate in aluminum, 40x20x0.6 mm.

- Numbering fixed by double tape with pressure sensitive adhesive and paper separator.



Sitzschale



Melamin-Farbe



Natürliche Buche

G3

ASIENTO CORRIDO SIN RESPALDO
BENCH STYLE BACKLESS SHELL SEAT

DIMENSIONES
DIMENSIONS



A: 310 mm
B: 45 mm
C: 450 mm

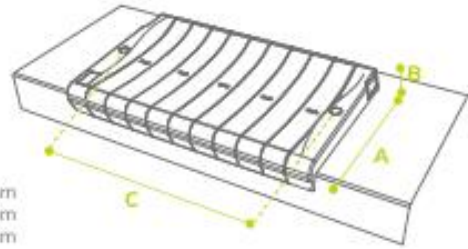

A: 310 mm
B: 45 mm
C: 450 mm

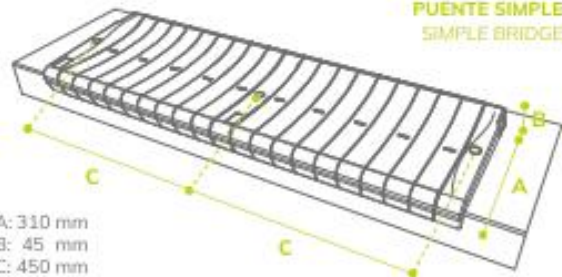

PUENTE SIMPLE
SIMPLE BRIDGE



A: 310 mm
B: 45 mm
C: 500 mm

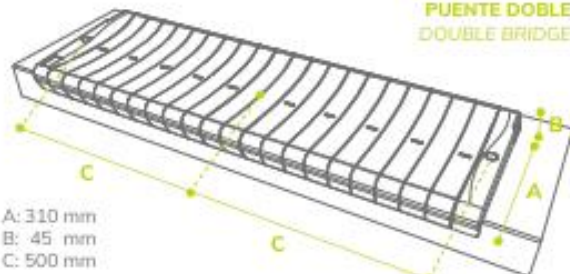

PUENTE DOBLE
DOUBLE BRIDGE

SOBRE GRADA
DIRECTLY ON STEP

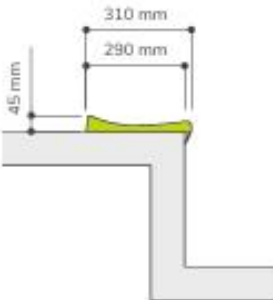

SOBRE BANCO METÁLICO
ON METALLIC BENCH

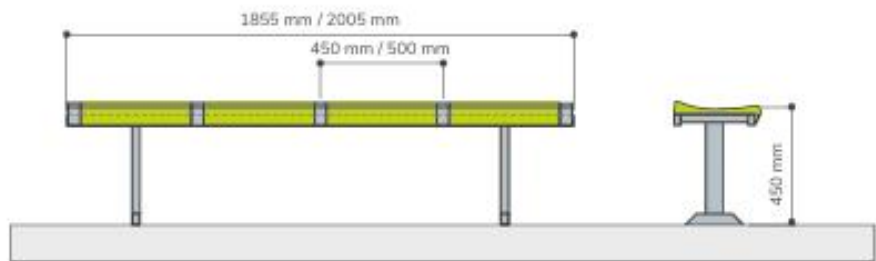

INFORMACIÓN:

Asiento sin respaldo, de dos piezas: asiento y puentes de unión, para realizar bancos corridos en disposición lineal sin límite de longitud. Para gradas convencionales y tribunas metálicas (telescópicas o desmontables).

INFORMATION:

Bench style seat, without backrest, of two parts: seat and connection bridges, to form benches without length limit. For conventional and metallic grandstands (telescopic or dismountable).

COMPLEMENTOS COMPLEMENTS

Numeración
Numbering

PUNTOS DE ANCLAJE ANCHORING POINTS

2 Puntos de anclaje laterales
2 Lateral anchoring points



G3
Mount Prospect Ice Arena, Illinois, EEUU.
Mount Prospect Ice Arena, Illinois, USA.

FARVER

COLORES DISPONIBLES:

Available Colours:

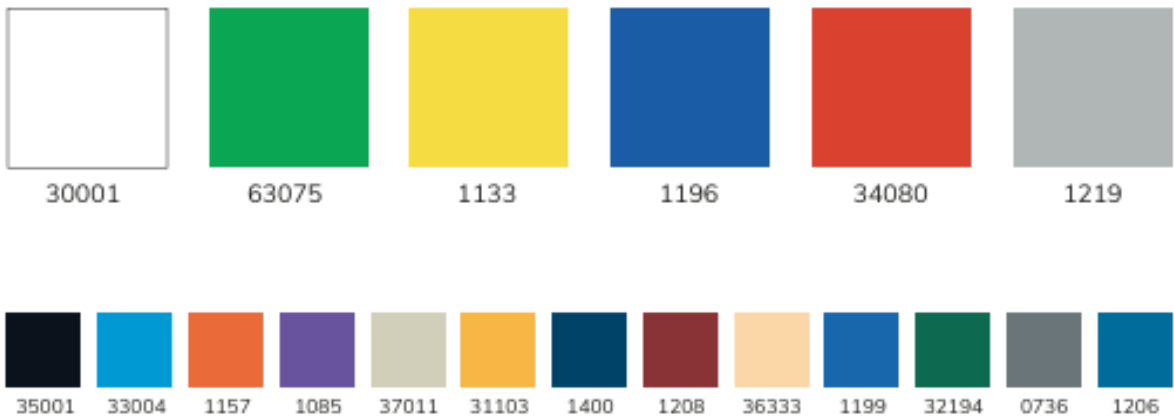

Fabricamos en cualquier color de la gama RAL que sea técnicamente posible.

We manufacture in any RAL colour technically available.



- Por favor, consultar condiciones de pedidos mínimos por color / modelo con nuestro departamento comercial.
- Please, contact our commercial department for information about minimum orders of each colour / model.
- Colores orientativos, pueden existir leves variaciones entre este impreso y el color del producto.
- Slight colour differences may occur between this print and the product.

Fibreglass brackets



Made of polypropylene copolymer as well as 30% fibreglass load. This delivers many advantages as compared to metallic supports: material is 100% rustproof and it does not need to be galvanized.

Recommended particularly for installation in rainy places with a high degree of salt in the air and dampness – for example, sports venues that are close to the sea. High resistance to considerable spectator use (as well as vandalism).

Brackets with 5 fixing points between the seat and support and 3 anchoring points to the step.

Options:

- Directly on step bracket.
- Floor mounted.
- Riser mounted. As an option, the supplements can be assembled together to form the necessary shaft length according to each grandstand profile.

Metallic brackets



All of the seats are designed to permit a wide range of metallic brackets that in turn enables them to be fixed onto any grandstand profile. (See each seat for more info).

In cold laminated steel tube S275, hot galvanised at 450° or cathophoretic coating; with an option of being oven painted; mono-arm with base plate in 3 anchoring points, which enables them to be fixed to any grandstand profile, with 5 fixing points situated between the seat and support.

Options:

- Floor mounted.
- Riser mounted .
- On metallic benches, either with or without being fixed to the floor. From 2 to 5 seats are possible.
- Custom-built – special brackets following project requirements.



Estadio Filadelfia, Turin, Italia.
Filadelfia Stadium, Turin, Italy.



Estadio Leo Lagrange, Toulouse, Francia.
Leo Lagrange Stadium, Toulouse, France.

Asientos Seats

Fabricados mediante inyección en molde en plástico estabilizado de alta calidad (polipropileno copolímero). Las carcasas quedan cerradas en todo su perímetro de apoyo sobre la grada para facilitar la limpieza y evitar la acumulación de suciedad en la base. Todas las carcasas disponen de desagües diseñados para drenar los líquidos del asiento.

Características Generales

Asientos diseñados para cumplir los siguientes requisitos:

- Resistencia antivandálica.
- Confortabilidad.
- Estética.
- Rapidez de instalación sobre cualquier superficie (hormigón, madera, metal).
- Fácil limpieza.
- Minimizar las tareas de mantenimiento

Moulded by injection in stabilized high quality copolymer polypropylene. Seats are sealed around their entire perimeter to prevent dirt from accumulating inside the seats, and in turn making them easy to clean. All the seats count with central drainage.

Main Characteristics

Our seats have been designed according with the following requirements:

- High resistance to vandalism.
- Comfort.
- Aesthetical.
- Quick to install on any surface (concrete, wood, metal).
- Easy to clean.
- Minimum maintenance costs.

COMPLEMENTOS

Numeración
Apoyabrazos
Logo
Acolchado

PUNTOS DE ANCLAJE

1 Punto de anclaje central
2 Puntos de anclaje laterales
4 Puntos de anclaje

COMPLEMENTS

Numbering
Armrest
Logo
Upholstery

ANCHORING POINTS

1 Central anchoring point
2 Lateral anchoring points
4 Anchoring points



SOSTENIBILIDAD: Sustainability:

Nuestro objetivo es que nuestros asientos sean **sostenibles**, reduciendo cada año las emisiones de efecto invernadero, reduciendo los recursos necesarios y reutilizando materiales. Por este motivo formamos parte de alianzas junto a otras empresas del sector con objetivos comunes, como las asociaciones empresariales **Envalora** y **Anaip**.

¿Qué hacemos? Estas son nuestras principales acciones en cada fase del proyecto:

Our aim is to make our seats **sustainable**, reducing greenhouse gas emissions each year, reducing the resources required and reusing materials. For this reason we are part of alliances with other companies in the sector with common objectives, such as the business associations **Envalora** and **Anaip**.

What do we do? These are our main actions in each phase of the project:

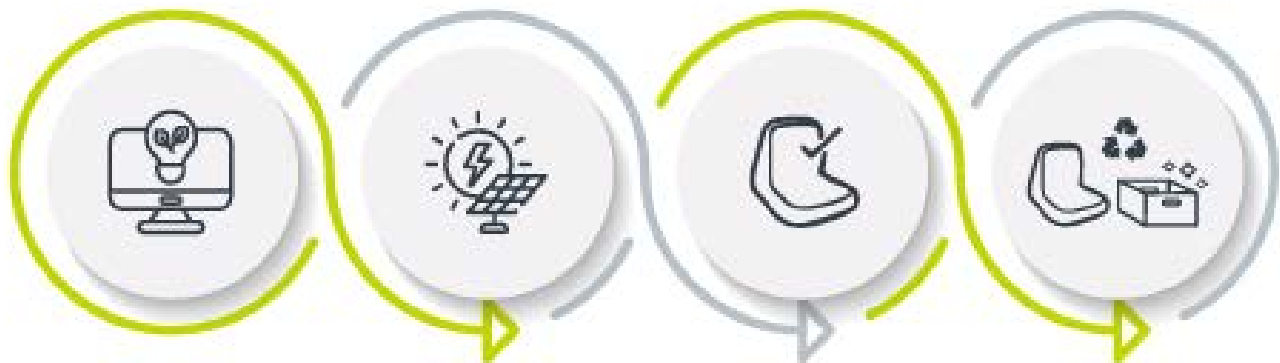

DISEÑO

Análisis y diseño del producto para que sea sostenible durante su ciclo de vida:

- Materiales que favorezcan su durabilidad, reciclabilidad, priorizando el consumo de materiales reciclados.
- Diseño del producto con peso, formas y tamaño para optimizar su transporte y embalaje eficiente.
- Priorizamos nuestra colaboración con proveedores locales.

DESIGN

Analysis and design of the product to be sustainable throughout its life cycle:

- Materials that favor their durability and recyclability, prioritizing the use of recycled materials.
- Product design with weight, shapes and dimensions to optimize its transport and efficient packaging.
- We prioritize collaboration with local suppliers.

PRODUCCIÓN

• **Panels fotovoltaicos** en nuestras instalaciones que nos permiten que parte de nuestra producción proceda de Energías Renovables.

• **Uso eficiente del agua:** Reutilizamos agua con un circuito cerrado y controlado. Canalizamos el agua de lluvia facilitando el ciclo del agua.

• **Uso de vehículos eléctricos** en planta de producción y almacén.

PRODUCTION

• **Photovoltaic panels** in our facilities that allow us to use part of our production from renewable energy sources.

• **Efficient use of water:** we reuse water in a closed and controlled circuit. We channel rainwater to facilitate the water cycle.

• **Use of electric vehicles** in the production plant and warehouses.

PRODUCTO FINAL

• **Durabilidad y resistencia.** Los asientos son artículos que tienen una vida útil muy larga, de años.

• **Uso de embalajes con alto contenido de material reciclado.**

• **Su mantenimiento y limpieza está libre de productos químicos,** simplemente se utilizan aire comprimido o agua.

• **Fabricamos asientos con hasta el 100% de material reciclado,** bajo demanda y según las características del proyecto.

FINAL PRODUCT

• **Durability and resistance.** Seats are items that have a very long useful life, of several years.

• **Use of packaging with a high content of recycled material.**

• **Their maintenance and cleaning are free of chemicals,** simply using compressed air or water.

• **We manufacture seats with up to 100% recycled materials on demand and according to the characteristics of the project.**

RECUPERACIÓN Y RECICLADO

• **Reciclamos el plástico** procedente del proceso productivo en la fabricación de otras piezas.

• **Aderidos a la asociación de empresas Envalora** para aumentar la circularidad de los envases.

• **Evitamos la emisión de medioambiente de partículas de plástico (granul),** Daptad está adherido a OCS (Operation Clean Sweep - Cero Partículas de Granul) una iniciativa mundial que está apoyada por el Ministerio para la Transición Ecológica del Gobierno de España.

RECOVERY AND RECYCLING

• **We recycle and reuse the plastic** from the production process. We recover production waste in the manufacture of other plastic parts.

• **Reuse and management of packaging and packaging waste.** Membership in the Envalora business association to increase the circularity of packaging.

• **We avoid the emission of plastic particles into the environment.** Daptad is a member of OCS (Operation Clean Sweep - Zero Plastic Granules) a global initiative supported by the Ministry of Ecological Transition of the Spanish Government.





ASIENTOS CON MATERIAL RECICLADO HASTA EL 100%
Seats made of up to 100% recycled material

PRODUCTOS 100% RECICLABLES
100% recyclable products



CALCULAMOS Y REDUCIMOS NUESTRA HUELLA DE CARBONO TODOS LOS AÑOS. REGISTRAMOS NUESTROS DATOS ANUALES Y NUESTRO COMPROMISO PARA REDUCIRLA SEGÚN LAS ESPECIFICACIONES DEL MINISTERIO PARA LA TRANSICIÓN ECOLÓGICA, DEL GOBIERNO DE ESPAÑA.

ADHERIDOS A LA INICIATIVA **OCS (OPERATION CLEAN SWEEP - CERO PÉRDIDAS DE GRANZA)** UN PROGRAMA VOLUNTARIO PARA EVITAR LA EMISIÓN DE PARTÍCULAS DE PLÁSTICO AL MEDIOAMBIENTE.

ADHERIDOS A ENVALORA - JUNTO A MÁS DE 800 EMPRESAS DE LA QUÍMICA, LOS PLÁSTICOS, EL METAL Y LA CONSTRUCCIÓN - AUMENTAMOS LA CIRCULARIDAD DE LOS ENVASES, INCREMENTANDO SU REUTILIZACIÓN Y EVITANDO QUE SE DESECHEN EN EL MEDIOAMBIENTE.

REGISTRAMOS NUESTRO CONSUMO DE PLÁSTICO RECICLADO EN LA PLATAFORMA MORE (MOVILIZADOS POR EL PLÁSTICO) DE EUROPEAN PLASTICS CONVERTERS | EUPC QUE MONITORIZA EL USO DE MATERIAL RECICLADO POR PARTE DE LOS TRANSFORMADORES DE PLÁSTICOS.

WE CALCULATE AND REDUCE OUR CARBON FOOTPRINT EVERY YEAR. WE RECORD OUR ANNUAL DATA AND OUR COMMITMENT TO REDUCE IT ACCORDING TO THE SPECIFICATIONS OF THE MINISTRY OF ECOLOGICAL TRANSITION OF THE SPANISH GOVERNMENT.

MEMBERSHIP IN THE **OCS INITIATIVE (OPERATION CLEAN SWEEP - ZERO PELLET LOSS)**, A VOLUNTARY PROGRAM TO PREVENT THE EMISSION OF PLASTIC PARTICLES INTO THE ENVIRONMENT.

MEMBERSHIP IN ENVALORA - TOGETHER WITH MORE THAN 800 COMPANIES IN THE CHEMICAL, PLASTIC, METAL AND CONSTRUCTION SECTORS - INCREASING THE CIRCULARITY OF PACKAGING, THEIR REUSE AND PREVENTING THEM FROM BEING DISCARDED INTO THE ENVIRONMENT.

WE REGISTER OUR CONSUMPTION OF RECYCLED PLASTIC ON THE MORE (MONITORING RECYCLATES FOR EUROPE) PLATFORM OF EUROPEAN PLASTICS CONVERTERS | EUPC WHICH MONITORS THE USE OF RECYCLED MATERIALS BY PLASTIC CONVERTERS.

PROYECTOS A MEDIDA:

Project customization:

Las necesidades de cada cliente y cada proyecto determinan la mejor solución técnica a aplicar en las distintas fases de diseño, fabricación e instalación, para garantizar el resultado final y la total satisfacción del cliente.

Integramos y desarrollamos todas las fases con recursos propios:

The needs of each client and each project determine the best technical solution to consider during the design, manufacturing and installation phases, which guarantee the final result and the total client satisfaction.

We integrate and develop all the phases with own resources:

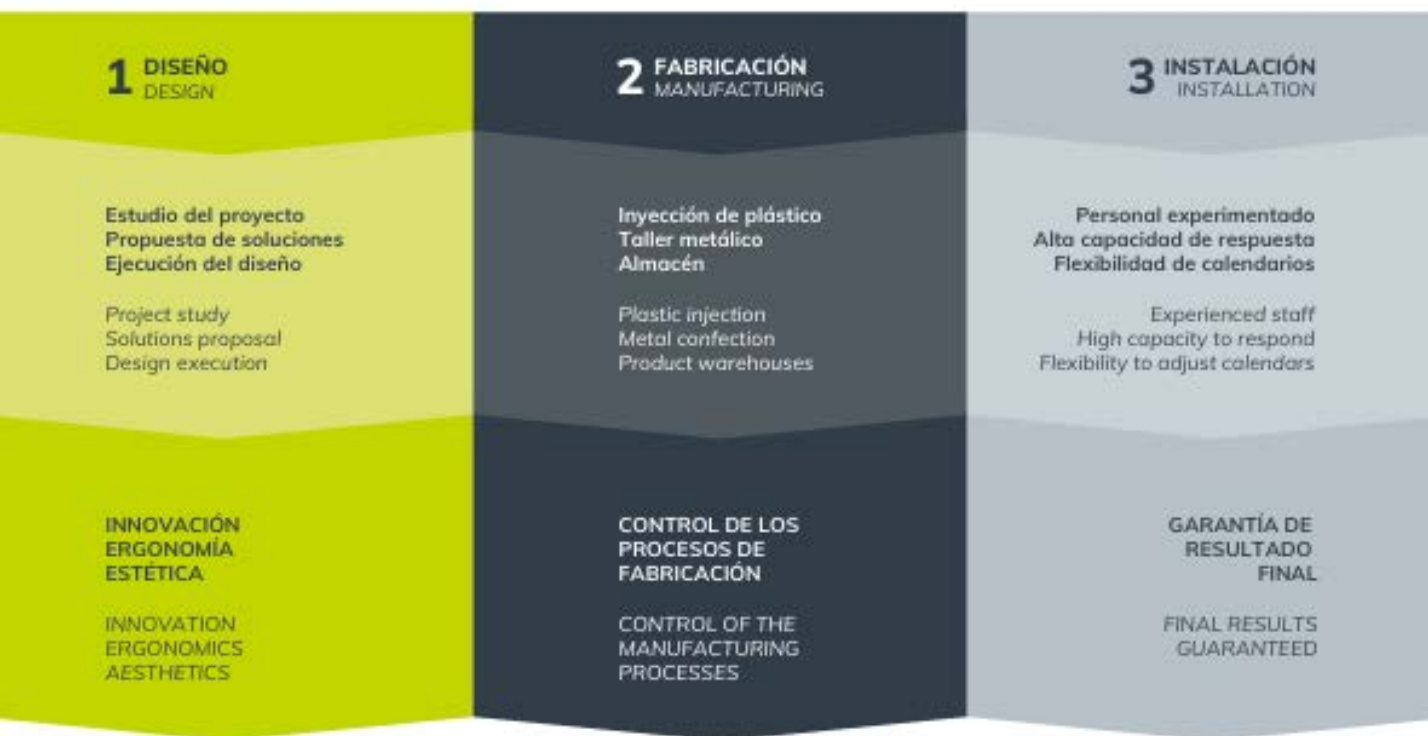

SOLUCIONES PERSONALIZADAS:

Aportamos creatividad y calidad, considerando la normativa vigente y los requisitos técnicos y estéticos de cada espacio.

Compartimos la ilusión y la confianza en el trabajo constante y bien hecho.

CUSTOMIZED SOLUTIONS:

We provide creativity and quality, according to current regulations and the technical and aesthetics requirements of each venue.

We share the excitement and commitment to achieve the best results.



Asientos CR6. Olivo Arena. Jaén, España.
CR6 seats. Olivo Arena. Jaén, Spain.

Resistencia a la luz
Light resistance

**Resistencia al uso público
severo (vandalismo)**
Resistance to severe
public use (vandalism)

Resistencia al fuego
Fire resistance

Testado antiUV, según Norma 13200/4, "Instalaciones para espectadores, parte 4."

UNE EN 12727 - certificados por Aidimme para el nivel 4: uso severo.

Todos nuestros asientos cumplen el test de inflamabilidad de mobiliario europeo EN 1021:2006 partes 1 y 2. Opcionalmente, se pueden fabricar según el estándar de otras normativas internacionales.

With anti-UV treatment, according to UNE EN 13200/4, "Spectator facilities -Seats -part 4"

Level 4, according to UNE EN 12727 Aidimme certificates are available.

All our stadium seats past the fire resistance test according to Furniture European regulations (EN 1021:2006 parts 1 and 2). Optionally we can produce them according to other international norms.

BJERRING

BJERRING

Kontakt os på:

TLF: +45 77345206

[Mail: salg@bjerring-sales.dk](mailto:salg@bjerring-sales.dk)

Se mere på:

bjerring-sales.dk -

bjerring-shop.dk -

bjerring-furniture.dk

BJERRING

Tykhøjvej 20 – Hal 5 – 7323 Give – Tlf. +45 77345206 –
mail: salg@bjerring-sales.dk - bjerring-sales.dk – sunswim.dk – bjerring-shop.dk –
bjerring-furniture.dk